

L3

AQUAVAR™
AQUAVAR™ 56
AQUAVAR™ II

Pumping System
Controllers



MAX.



3/4 NPT

Contents

Control Systems Overview	2
Standard AQUAVAR Controllers, 1 – 75 HP	3
AQUAVAR II Controllers, 1 – 75 HP	9
AQUAVAR Model 56 Controllers, 1 HP	11
Pump Control Applications	12
Pump Selection for VFD operation	18
Typical System Design	18

Control Systems Overview



It's where we're going

G&L Pumps, the world leader in stainless steel pump technology, now brings you the most complete line of pump specific variable frequency drive control systems available today. Both our AQUAVAR, AVII Series and AQUAVAR 56 controller product families are designed to meet the rigid requirements of pumps and pump systems, while providing you with lower investment and operating costs when compared to traditional pumping systems. We designed the AQUAVAR with the pump professional in mind.



AQUAVAR CONTROLLER

The AQUAVAR controller is a combination of a variable frequency motor drive (VFD) and a programmable logic controller (PLC) in one compact package, which can be either mounted on the fan cover of the TEFC pump motor, or on a wall or panel near the pump. Each AQUAVAR controller is pre-programmed with patented pump specific software. Wall mounted units enable the AQUAVAR controllers to be used with either surface or submersible pumps. AQUAVAR controllers are specifically designed to work with all configurations of centrifugal pumps, so they will match pump output to a wide range of varying system conditions while protecting the pump, the motor and the pumping system.

AQUAVAR MODEL 56 CONTROLLER

The AQUAVAR Model 56 controller combines many of the most popular features of the larger units, but in a smaller size to meet the requirements of NEMA 56 and 48 frame size motors. A removable programming pad is used which reduces the investment cost to the user. Available for up to 1 HP motors.



AQUAVAR II CONTROLLER

The AQUAVAR II combines the control software of the AQUAVAR with traditional wall mounted VFD packaging. The design is for higher horsepower applications and specific voltage input requirements, such as 575V, 200V, 208V, single phase up to 20 HP and three phase 208-230V up to 30 HP.

The AQUAVAR Controller meets these standard system requirements . . .

The G&L Pumps AQUAVAR controllers work with your pump to produce:

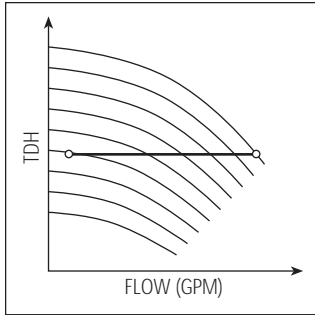

control for constant pressure with varying flow rates . . .

or

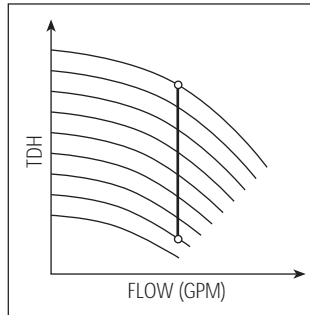

control for constant flow with varying TDH . . .

or

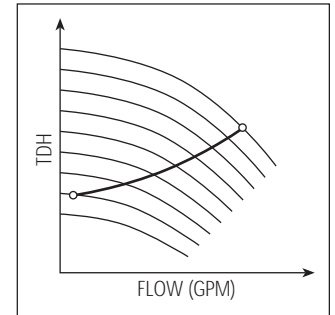

control to match a system curve.

While eliminating the need for . . .

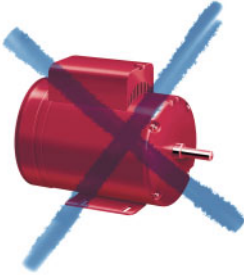

Jockey pumps and specialized motors



Separately purchased pressure sensors



Separate microprocessor sequencing systems



Separate control panels and inverters



Bypass lines and metering valves



Large supply tanks

Eliminate problems with the AQUAVAR Controller

Eliminate Run Out Cavitation

When centrifugal pumps are asked to produce more flow than their design allows, they will eventually destroy themselves through cavitation. The AQUAVAR controller prevents this by automatically starting the next pump of a multi-pump system, or shutting the pump down before damage can occur. No mechanical metering valves or flow restrictors are required.

Eliminate Shut Off Damage

Running a centrifugal pump with no flow will eventually heat the pumpage and may create seal failure or other damage. The AQUAVAR controller prevents this by automatically shutting down the pump when there is no demand in the system. No pressure regulation valve, mechanical by-pass lines and orifice plates are required.

Eliminate Wasted Energy

The chart below shows the amount of energy that is typically wasted when a single speed pump runs at low flows. The extra energy needed to create higher heads than the system requires is wasted. The AQUAVAR controller prevents this by automatically reducing motor speed at lower flow to match the requirements of the system. No large supply tanks are required.

Eliminate Control Panels

Most systems have an electrical panel with starters, protection against voltage fluctuation, faults, shorts and overloads. In a multi-pump system, relays, switches and other controls are also needed to sequence the pumps. The AQUAVAR controller eliminates this by providing soft start, complete electrical protection, and automatic sequencing without the need for a separate panel.

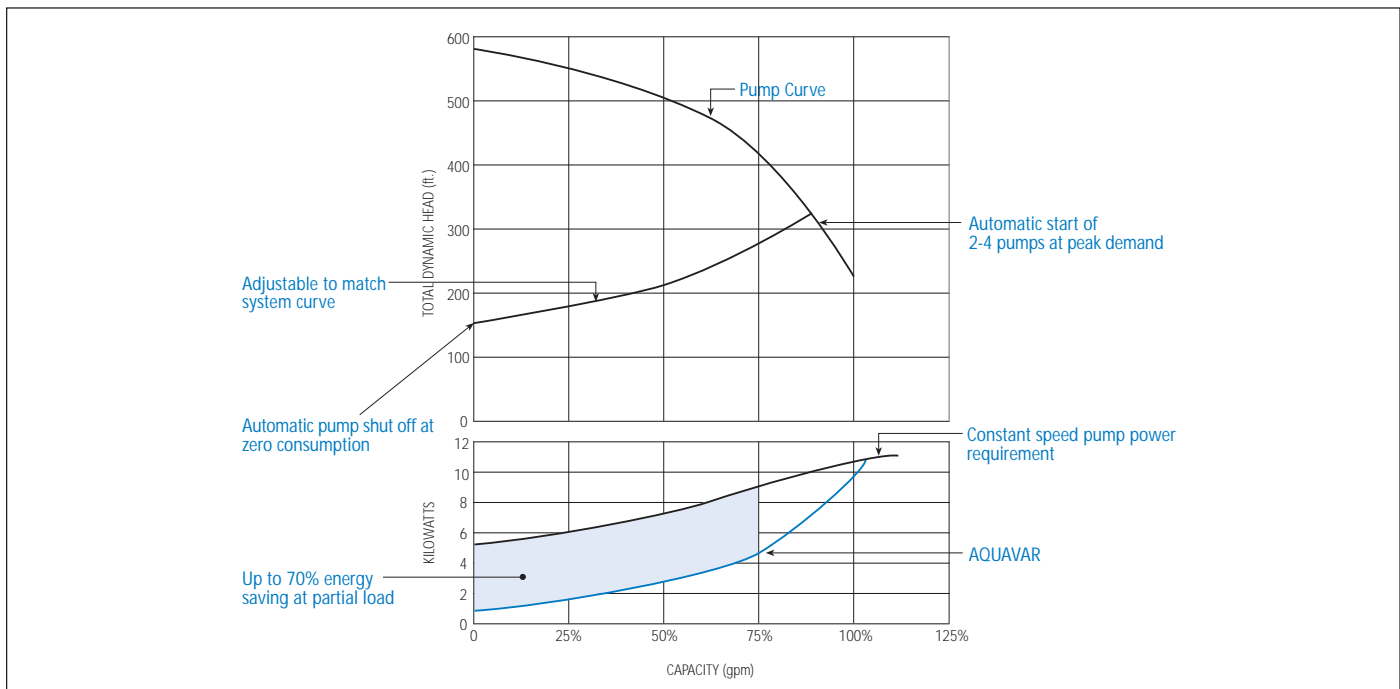

Example of Energy Savings on 15 HP Pump

% Capacity	Constant Speed KW	AQUAVAR Controller KW (System Curve)	Savings X	1/3 Year (2,920 hours)
25%	5.8 KW	1.8 KW	4.0 KW	11,680 KWH
50%	7.6 KW	3.2 KW	4.4 KW	12,848 KWH
75%	9.2 KW	5.7 KW	3.5 KW	10,220 KWH
First Year Energy Savings (constant running)				→34,748 KWH*

* Savings based on comparison of constant speed pump system versus variable speed controller. Savings are not guaranteed and will vary based on operation, usage and local energy rates. This is only a comparative example.

The additional investment in an AQUAVAR controller over a standard pump could be returned in energy savings by the first year!

The AQUAVAR Controller is easy to use.

Single Pump System

2 Wire it in.
(standard fuse box)

1 Pipe it up.
(standard piping)



3 Set pressure (psi).

4 Press start.

Multi-pump System (2-4)

1 Plumb to header(s)

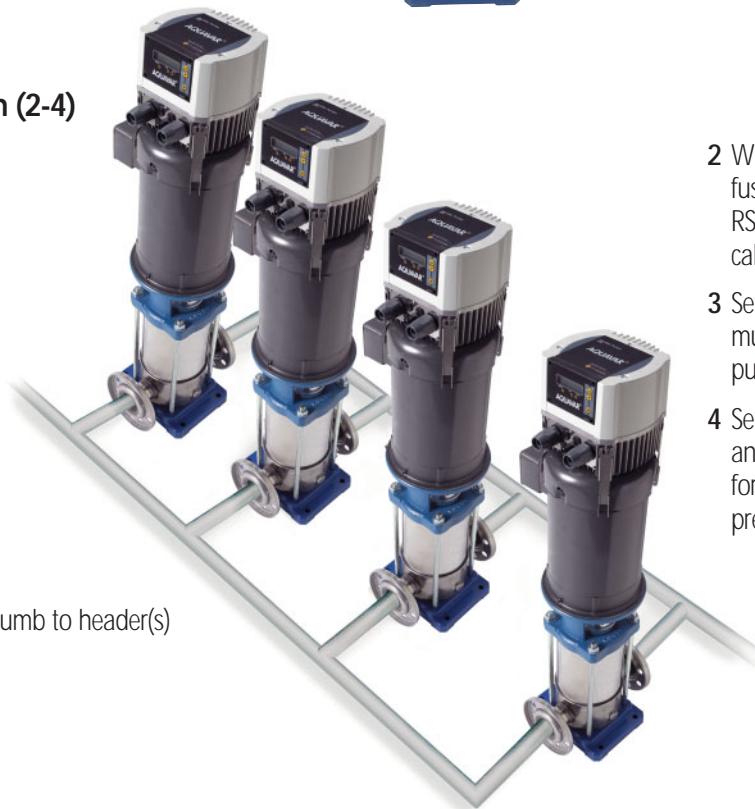

2 Wire each AQUAVAR to fuse box and connect RS-485 communication cable.

3 Set pressure (psi) and multi-pump mode on pump #1.

4 Set pump address and multi-pump mode for other pumps and press start.

- ✓ Automatically starts and stops lead and lag pumps to meet demand.
- ✓ Automatically alternates lead pump position for even use.
- ✓ Automatically stops all pumps when system demand is zero.
- ✓ Can be integrated into central control systems via special monitoring terminals.

Standard AQUAVAR Controllers: 2 – 30 HP Motor Mounted Versions

Available Configurations

Horsepower Range	Electrical Requirement
2 and 3	1 phase, 230 V
5, 7.5, 10, 15, 20, 25 and 30	3 phase, 460 V

Technical Data

Single Phase Version: 2 and 3 HP

Motor Rating: 3 phase, TEFC, 208 – 230 volt, 0 – 60 HZ, Class F insulation, NEMA design A or B

Power Supply: single phase input, 220 – 240 volt, $\pm 10\%$, 40 – 70 HZ

Three Phase Version: 5 HP to 30 HP

Motor requirements: 3 phase, TEFC, 460 volt, $\pm 10\%$, 0 – 60 HZ, Class F insulation, NEMA design A or B

Power Supply: 3 phase, 380 – 460 volt, $\pm 10\%$, 40 – 70 HZ

Pressure Transducer: 316 SS, 17-4 PH stainless steel, $\frac{1}{4}$ " NPT connection, shielded two wire cable, operating temperature -13° F to 250° F, supply voltage 7- 35 Vdc, 4 – 20mA output. Accuracy is .5% of full scale, proof pressure is 4 x full scale.

Display: Two line, 16 characters per line, LCD display. Easy to read pump language, pump on, system pressure, fault codes and system conditions are displayed.

Motor Speed: variable between 0 – 70 HZ, or maximum RPM at 60 HZ depending on speed rating of standard AC induction motor.

Ambient Temperatures (operating): 32 – 104° F (0 – 40° C),

Humidity: 50% relative at 104° F (non-condensing)

90 % relative at 68° F (non-condensing)

Inverter design: IGBT, output frequency is a sinus valuated Pulse Width Modulated (PWM)

Enclosure: NEMA 4, IP 55. Avoid excessive dust, corrosives or salts.

Approvals: UL, cUL, CE

Protection: Over/ Under voltage, motor overload, short circuit, ground fault, motor overheat (with thermistor), programmable no/low flow shut-down, low suction pressure, pump run-out.

Control: Analog input control (4 – 20mA) two point control based on pressure, flow or differential pressure.

Terminals: Dry relay contacts are available for pump run, pump error, low pressure switch, remote ON/OFF control, analog output 0 – 10 Vdc (system pressure) and full opened slave pump starter.

Multi-Pumps: RS485 communication SIO (local only) up to four pumps.

Alternate Input: Up to two transducers may be used with each controller. These may be pressure, flow, differential pressure, temperature or other 4 – 20mA signals.



Up to 15 HP Pump Mounted Version



20 to 30 HP Pump Mounted Version

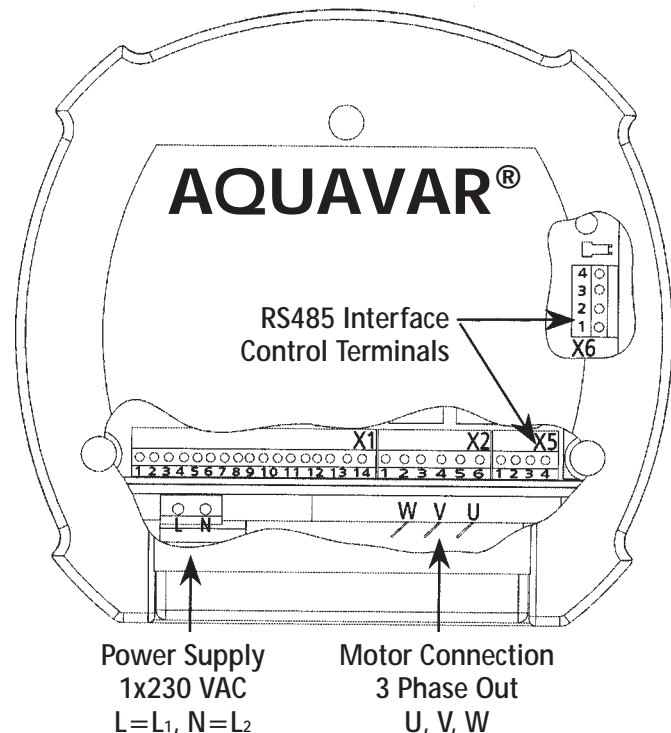

2-15 HP:

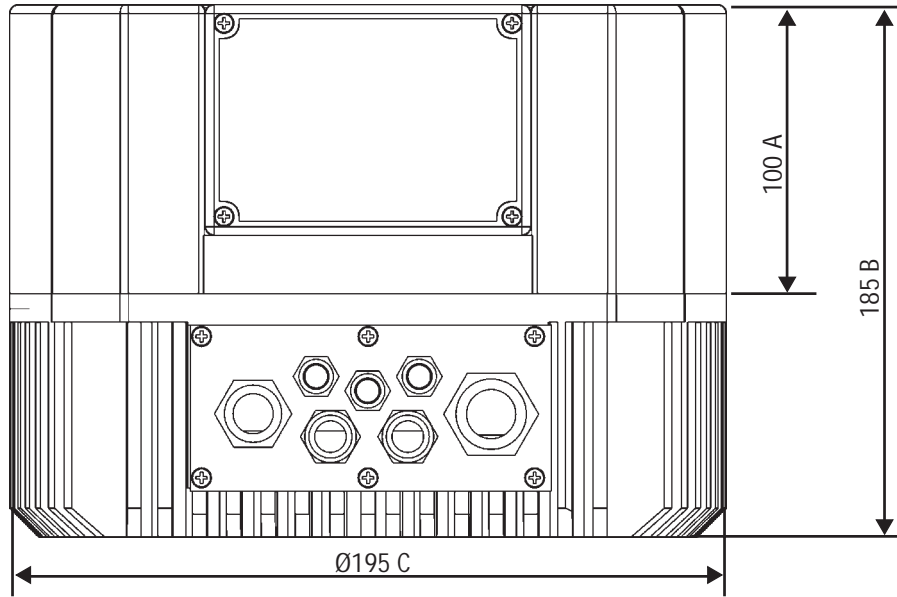

Dimension Table:

HP	Type	A	B	C	Weight
2	04168321	100	185	195	12 lbs.
3	04168331	100	185	195	12 lbs.
5	04168371	100	185	195	12 lbs.
7½	04168491	100	185	280	22 lbs.
10	04168501	100	185	280	22 lbs.
15	04168511	100	185	280	22 lbs.

Dimensions (mm)

Conversion to Inches:

(mm)	Inches*
100	3 ¹⁵ / ₁₆
185	7 ⁹ / ₃₂
195	7 ⁴³ / ₆₄
280	11 ¹ / ₃₂

*Approximate

20-30 HP:

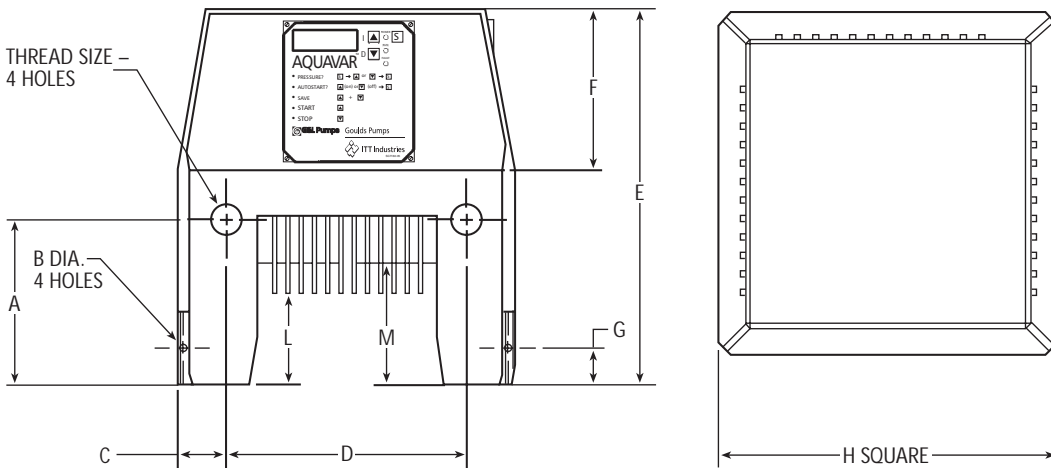

HP	A	B	C	D	E	F	G	H	J	K	L	M	Connector Hole Thread Size	Weight
20, 25, 30	5¾	⅜	2½	9	14	8¾	1¼	14	12¾	12¼	3	3½	(2) PG 16 mm (2) PG 29 mm	63

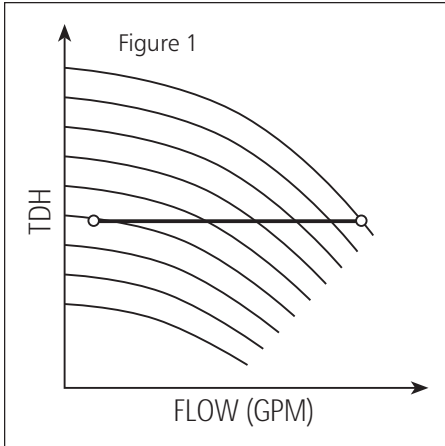

Control for constant pressure with varying flow rates.

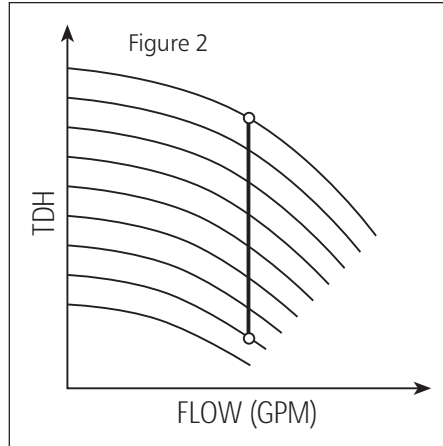

Control for constant flow with varying TDH.

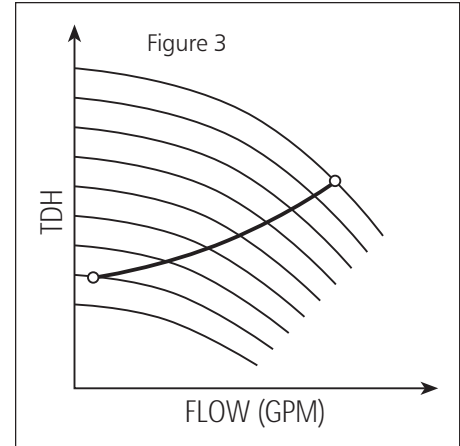

Control to match a system curve.

Control

The built in frequency inverter and microprocessor provides pump control based on pressure, differential pressure, or flow (Figures 1 and 2). The pressure control version stops the pump at zero consumption. (Small size pressure diaphragm tank may be required.) The discharge of the pump is being calculated via the speed indirectly and may be programmed to compensate for varying friction losses following a programmable system curve (Figure 3).

The AQUAVAR controller may be controlled externally with the required speed fed in by an external control system, with a 4-20mA analog signal.

To prevent unauthorized personnel from changing operating data, a password may be set up. The starting and stopping of the pump as well as setting of control parameters is done at the keyboard and shown at the LCD display of the drive head. The display is 2-lined and programmed for English, Spanish or French. There are also 3 LED's to indicate "PUMP READY", "PUMP RUNNING" and "FAULT" (Figure 4).

There are also terminals for remote start and stop as well as

relays to signal "running" and "fault". An analog signal to monitor speed or frequency and communicate with a central control system is also possible. (Figure 5)

Each AQUAVAR controller contains an individual microprocessor which controls the automatic operation of lead and lag pumps according to demand, alternation of lead and lag pumps, automatic start, and startup of the next pump when a pump gets out of order. No external controls are necessary. Each controller uses the same control logic. Therefore, different horsepowers and pump configurations may communicate together in the pumping system.

The voltage controlled (IGBT) frequency inverter supplies a sinus valuated pulse width modulated output voltage. It works with controlled sinusoidal current synthesis and a dynamic overcurrent limitation. The high switching frequency of 8 kHz prevents undesired noise from driving motors and can be adjusted according to motor requirements. Reactions to the feeder are prevented by a filter. Inverter cooling is enhanced by the motor fan.

There is also a memory for "fault" signals, operating hour counter, and an automatic start up of the pump as a test run.

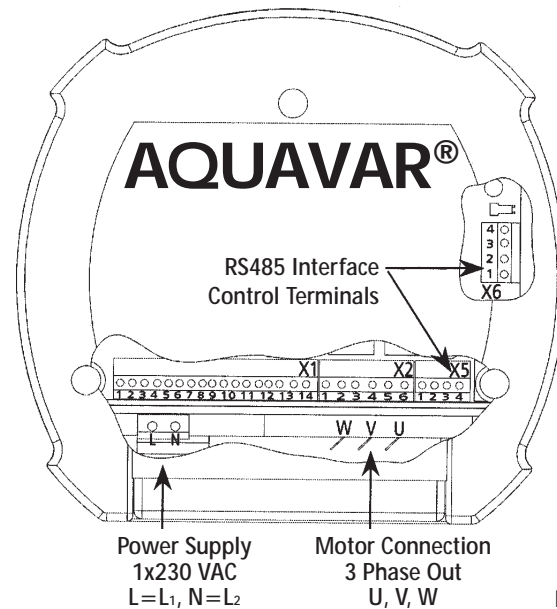

Figure 4

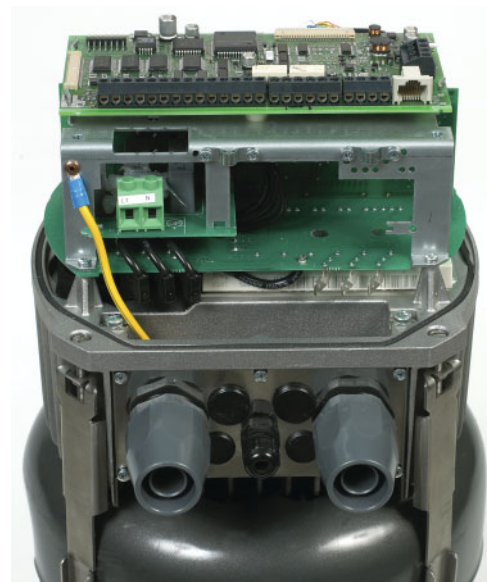

Figure 5



Overview

The AQUAVAR II series of pump controllers is a continuation of the standard motor mounted Aquavar, in a wall mounted NEMA 12 enclosure. It offers an extension of the Aquavar line when your application requires different input voltages, higher current loads, larger horsepower, or you need to operate in explosion proof areas. This controller also provides a great opportunity for a submersible variable speed turbine systems.

Technical Data

Single Phase (200 – 230 volt) Version: 1 HP through 10 HP.

Motor requirements: 3 phase, 208 – 230 volt, 0 – 60 HZ, Class B or F insulation, NEMA design A or B, standard AC induction motor.

Power Supply: Single phase input, 200 – 230 volt, \pm 15%, 40 to 70 HZ.

Three Phase (200 – 230 volt) Version : 1 HP to 20 HP

Minimum Motor requirements: 3 phase, 208 – 230 volt, 0 – 60 HZ, Class B or F insulation, NEMA design A or B, standard AC induction motor.

Power Supply: 3 phase, 200 – 230 volt, \pm 15%, 40 – 70 HZ.

Three Phase (460 volt) Version: 1 HP through 75 HP.

Motor requirements: 3 phase, 460 volt , 0- 60HZ, Class B or F insulation, NEMA design A or B, standard AC induction motor.

Power Supply: 3 phase, 380 – 460 volt, \pm 15%, 40 – 70 HZ.

Three Phase (575 volt) Version: 1 HP through 75 HP.

Motor requirements: 3 phase, 575 volt , 0 – 60 HZ, Class F insulation, NEMA design A or B, standard AC induction motor.

Power Supply: 3 phase , 575 volt, \pm 15%, 40 – 70 HZ.

Pressure Transducer: 316 SS , 17-4 PH stainless steel, 1/4" NPT connection, shielded two wire cable, operating temperature – 13° F to 250° F, supply voltage 7- 35 Vdc, 4 – 20mA output. Accuracy is .5 % of full scale, proof pressure is 4 x full scale. Two transducer inputs available. Any 4 – 20mA signal may be used (pressure, flow, temperature, differential pressure, etc.)

Display: Two line, 16 characters per line, LCD display. Easy to read pump language, pump on, system pressure, fault codes and system conditions are displayed.

Motor Speed: Variable between 0 – 70 HZ or maximum RPM at 60 HZ depending on speed rating of standard AC induction motor used.

Ambient Temperatures (operating): 0 – 104° F (0 – 40° C).

Altitude: 3300 feet above sea level for full HP, De-rate 2 % each 1000 ft. above 3300 ft.

Humidity: 0 – 95 % , non-condensing.

Inverter design: IGBT, output frequency is a sinus valuated Pulse Width Modulated (PWM). Adjustable carrier frequency.

Enclosure: NEMA 12. General indoor industrial use. Avoid excessive moisture, dust, corrosives or salts. (NEMA 4, outdoor enclosures available).

Agency Listing: UL, cUL, CE

Protection: Over/ Under voltage, motor over-current, short circuit, ground fault, motor overheat, programmable no/low flow shut-down, low suction pressure, pump run-out, low NPSHa.

Control: Analog input control (4 – 20mA) two point control based on pressure, flow or differential pressure.

Terminals: Dry relay contacts are available for pump run, pump error, low pressure switch, remote ON/OFF control, analog output 0 – 10 Vdc (system pressure).

Multi-Pumps: RS485 communication SIO (local only), up to four controllers. Slave pump feature not available.

Dimensions and Weights

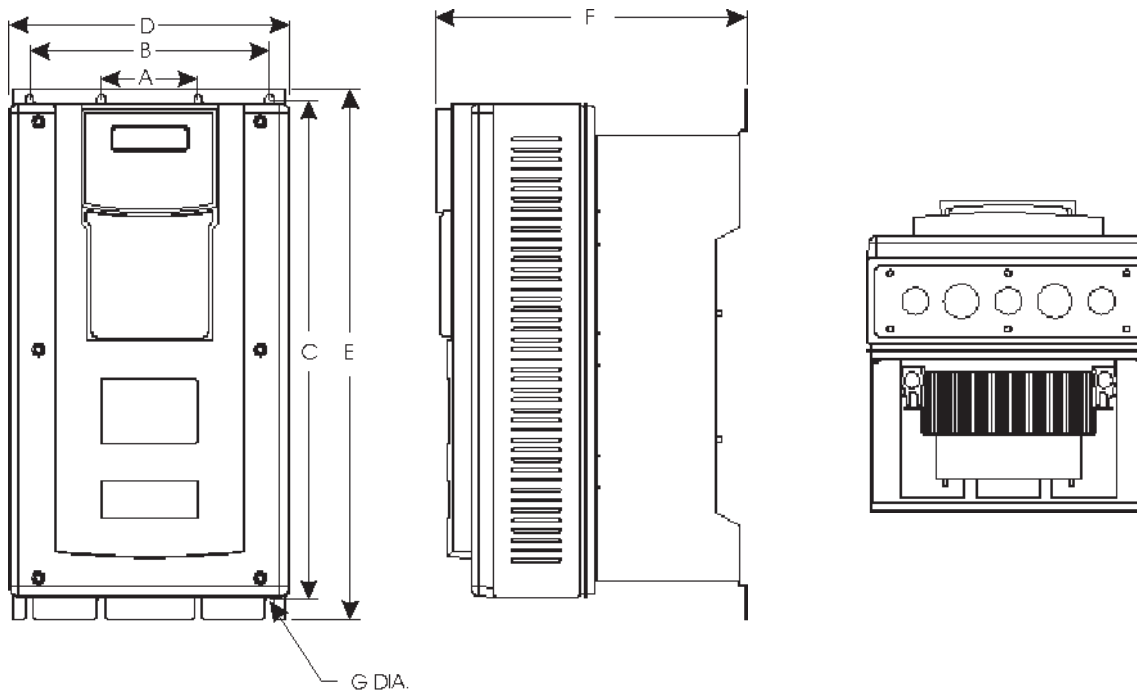

HP Rating	A in (mm)	B in (mm)	C in (mm)	D in (mm)	E in (mm)	F in (mm)	G in (mm)
1 – 10 (230 – 3) 1 – 5 (230 – 1) 1 – 20 (575)	3.20 (81.28)	7.88 (200.15)	16.50 (419.10)	9.32 (236.70)	17.44 (442.98)	12.08 (306.71)	0.28 (7.11)
15 – 20 (230 – 3) 7½ – 10 (230 – 1) 25 – 40 (460) 25 – 40 (575)	3.20 (81.28)	7.88 (200.15)	19.25 (488.95)	11.44 (290.53)	20.19 (512.83)	13.51 (343.20)	0.28 (7.11)
25 – 75 (460) 25 – 75 (575)	3.20 (81.28)	7.88 (200.15)	28.00 (711.20)	12.68 (322.07)	31.37 (796.80)	14.00 (355.60)	0.42 (10.67)

Note that the E-dimension in the 50-75 HP is maximum overall height to the conduit box rather than the bottom of the foot.

Weights of Models - NEMA 12 Enclosure

Power Rating HP	Weight	
	Pounds	Kilograms
1	24.0	10.9
2	24.0	10.9
3	24.0	10.9
5	24.0	10.9
7½	24.0	10.9
10	24.0	10.9
15	28.0	12.7

Power Rating HP	Weight	
	Pounds	Kilograms
20	28.0	12.7
25	52.0	23.6
30	52.0	23.6
40	60.0	27.2
50	107.0	48.6
60	107.0	48.6
75	107.0	48.6

Overview

The AQUAVAR Model 56 controller features the same control methods just described for the standard AQUAVAR controllers, but in a smaller package for use with 1 horsepower pumps. Differences are as follows. (For other specifications refer to the previous pages on the standard sizes or refer to the instruction manual.)

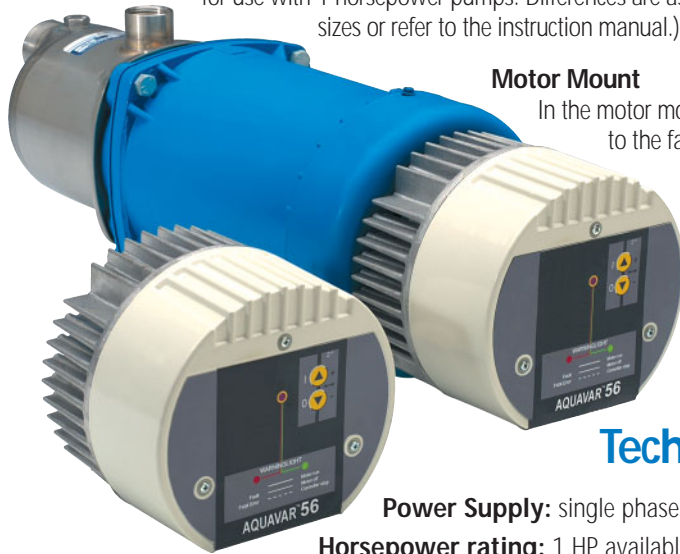

Motor Mount

In the motor mounted version, the AQUAVAR Model 56 controller uses a single bolt to attach to the fan cover of a NEMA 56 or 48 frame TEFC motor.

Programming Pad

On the AQUAVAR Model 56 controller, programming is completed with a removable pad, which is normally not sold with the controller. This pad is used by the installing technician, but would seldom be used afterwards. It is possible for the user to change the set pressure of the system and correct faults without the programming capability. The control pad is available separately.

Technical Data

Power Supply: single phase input, 220 – 240 volt, \pm 10%, 40 to 70 HZ.

Horsepower rating: 1 HP available (1.0 Service Factor).

Motor Rating: 3 phase only, 208 – 230 volt, 0 – 60 HZ, TEFC, Class F insulation, NEMA design A or B.

Pressure Transducer: 0 – 100 psi, stainless steel body , ceramic diaphragm, NEMA 4X outdoor rated, 2 wire shielded cable, 5VDC , signal range .5 – 4.5 VDC ratiometric type.

Display: LED for Run, Fault and pump on. Removable field programming pad.

Motor Speed: Variable between 0 – 60 HZ , or maximum RPM at 60 HZ depending on speed rating of standard AC induction motor rating.

Ambient Temperatures (operating): 32 – 104° F (0 – 40° C)

Humidity: 50% relative at 104° F (non-condensing), 90% relative at 68° F (non-condensing).

Inverter Design: IGBT, output frequency is a sinus valuated Pulse Width Modulated (PWM).

Enclosure: NEMA 4, IP 55. Avoid excessive dust, corrosives or salts.

Approvals: UL, cUL, CE

Protection: Over/ Under voltage, motor overload, short circuit, ground fault, motor overheat (with thermistor), programmable no/low flow shut-down, low suction pressure, pump run-out. (Set for 10 psi.)

Control: Analog input control. Two-point control based on pressure or differential pressure.

Terminals: Dry relay contacts are available for slave pump, low pressure switch, remote ON/OFF control, motor thermistor.

Multi-Pumps: RS485 communication SIO (local only).

Pump Control Applications

Typical Pump Sensor Types and Locations

Pump Discharge

- Differential Pressure** – Compensation for friction losses in closed loop systems.
- Pressure** – Constant pressure or system curve.
- Flow meter or orifice plate** – Constant flow
- Level control** – Sensors for tank filling.

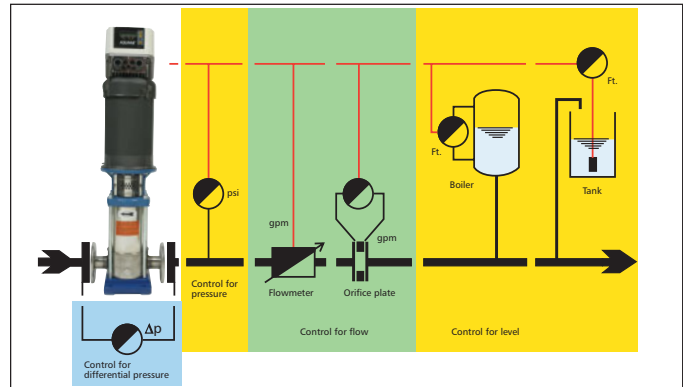

Pump Suction

- Pressure** – Compensation for changes in suction pressure or system curve. Tank or basin draining applications.
- Level control** – Suction side tank draining sensor. Used for wet well systems.

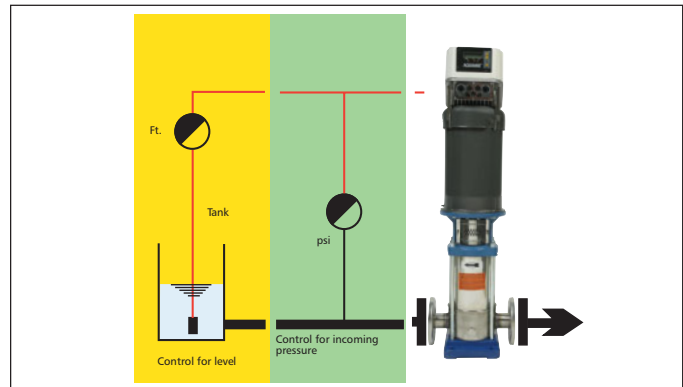

Submersible and Turbine Pump Applications

- Submersible well, turbine, effluent or sewage pumps.
- Operates with motor lead lengths up to 60 feet as standard.
- Wall mounted AQUAVAR controller.
- Optional filter is used for up to 1000 feet of motor lead lengths. (Contact factory for applications assistance.)

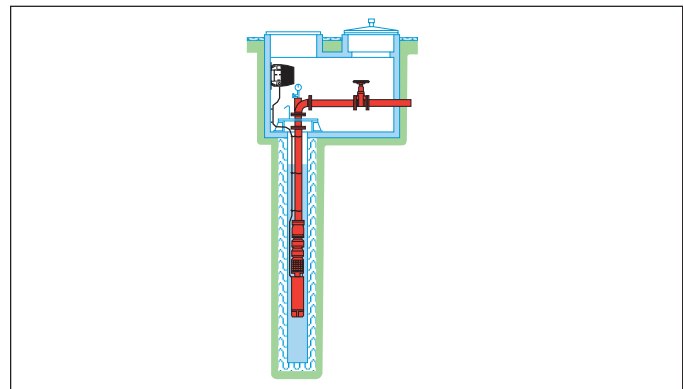

Effluent and Sewage Pump Applications

- Standard systems use full speed pumps with level switches for start and stop.
- Large basins are used to reduce number of starts.
- AQUAVAR controllers save energy with low pump speed to match incoming flow.
- System basins can be up to 80% smaller.
- Constant flow reduces build-up of pipe sediment.
- Maintain constant wet well level even with varying in-flow.
- AQUAVAR's turn off pumps with no incoming flow.

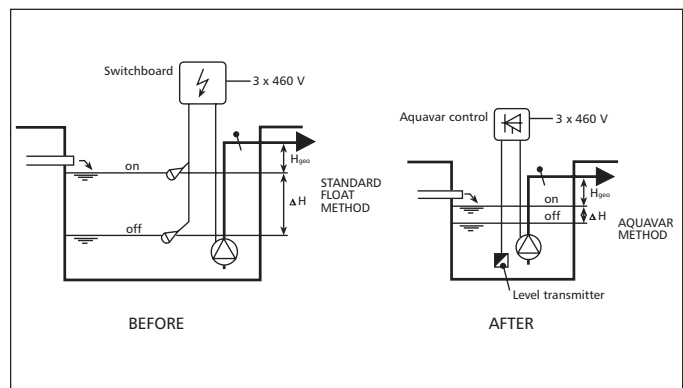

Typical Pump Sensor Types and Locations

Change Pressure or Flow Set Point

- The AQUAVAR controller has the capability to receive input from two analog (4-20 ma) devices at the same time.
- Input #1 from pressure transducer regulates pressure.
- Input #2 from external source changes set point with system changes.
- Input #2 can be for a fixed set point with external contact or variable with an actual value.
- Set two pressure points with one transducer.
- Great for irrigation control pressures or process control.

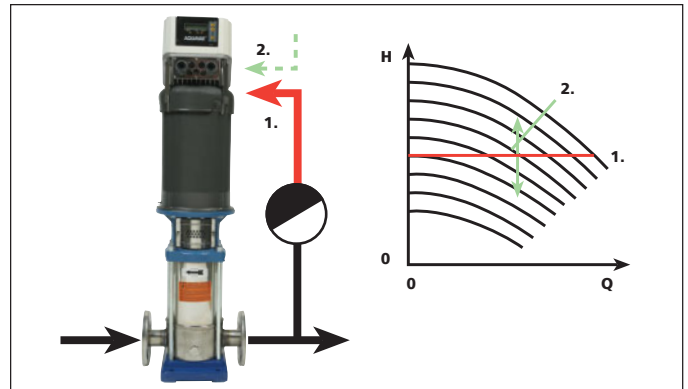
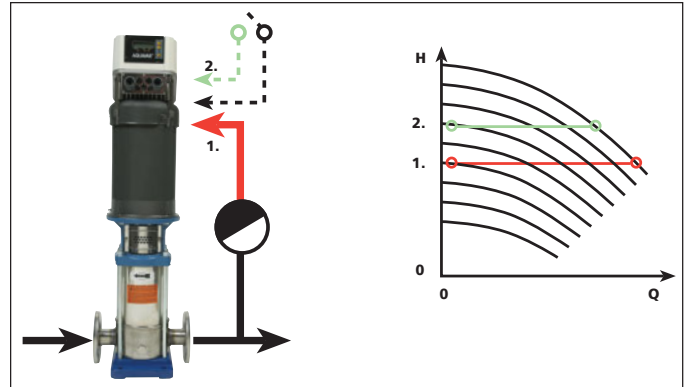

Change Pressure Based on Suction Condition

- Input #1 from pressure transducer regulates pressure.
- Input #2 from suction reduces pump speed as suction pressure drops.
- When well or tank level drops, the speed of your motor will slow down. This could prevent overpumping of the well or tank.

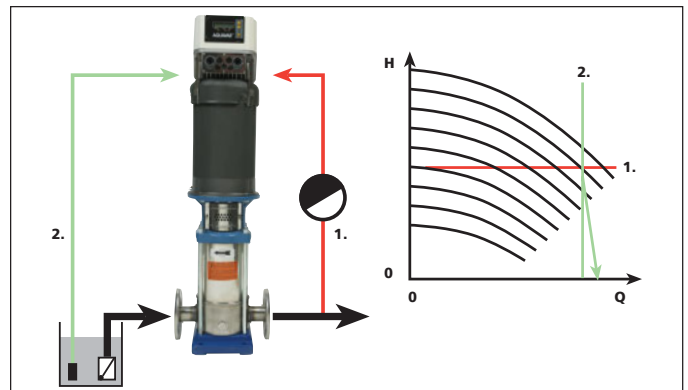

Pump Control Applications

Change Pressure Based on Flow

- When flow reaches maximum load or pump capacity.
- Pump slows down to maintain flow but reduced pressure.

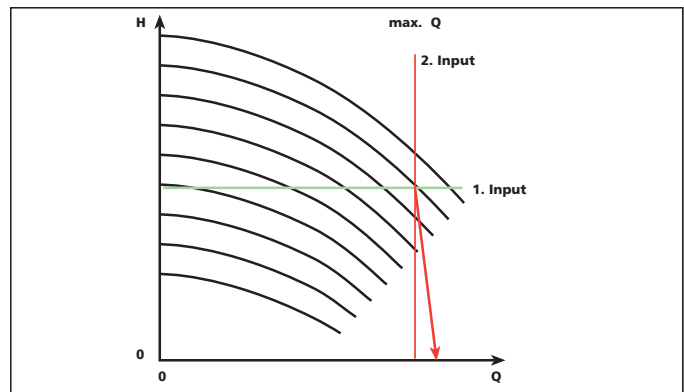
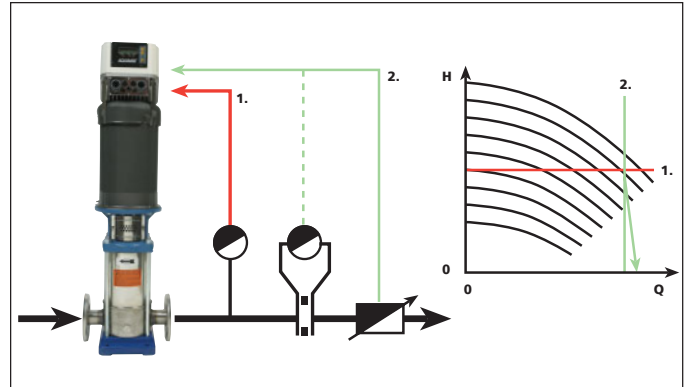

Mixing of Two Fluids Based on Flow

- Flow sensor on #1 measures flow of fluid #1.
- Flow sensor #2 adjusts speed of pump to mix a set percentage of fluid #2.

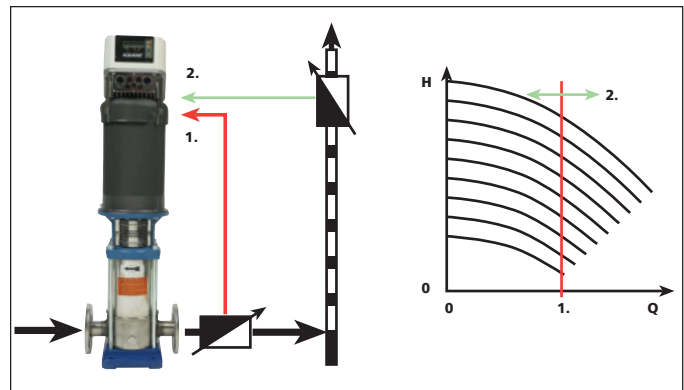

Suggested Pump Control Applications

Multi-Story Building Water Supply

- An AQUAVAR controller system offers independent zone control.
- Automatic lead/lag for even pump wear.
- Automatic friction loss compensation for higher floors.
- Constant pressure with varying demands.
- Automatic pump shut off at zero demand.
- Eliminates the need for large supply tanks.

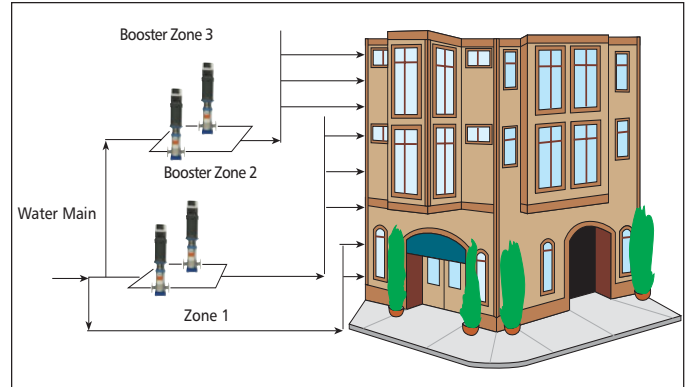

Reverse Osmosis Filtration Systems

- An AQUAVAR controller system can be set up for either constant pressure or constant flow through the filtration system.
- The pump is protected from low flow damage when the filter becomes clogged.
- Automatic system shut off signals operator to change filters.
- Automatic pump speed change to increase pressure for additional banks of filters for higher demand rates.

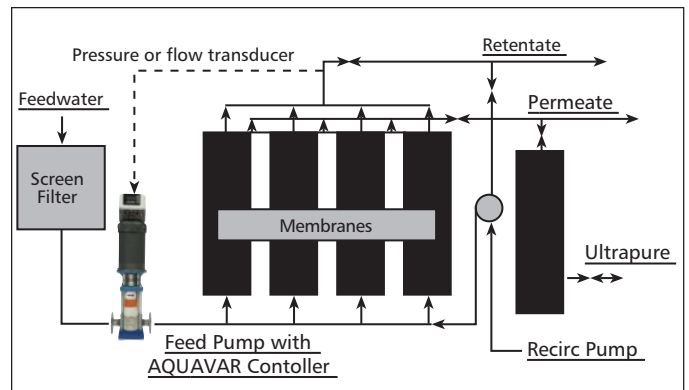

Boiler Feed Systems

- An AQUAVAR controller maintains constant pressure to the boiler at varying demand rates.
- The boiler level control switch can be connected directly to the controller for on/off control.
- No by-pass lines, metering valves or automatic "Clayton" type valves are required.
- The AQUAVAR controller automatically protects the pump from damage in low NPSH or run out conditions.

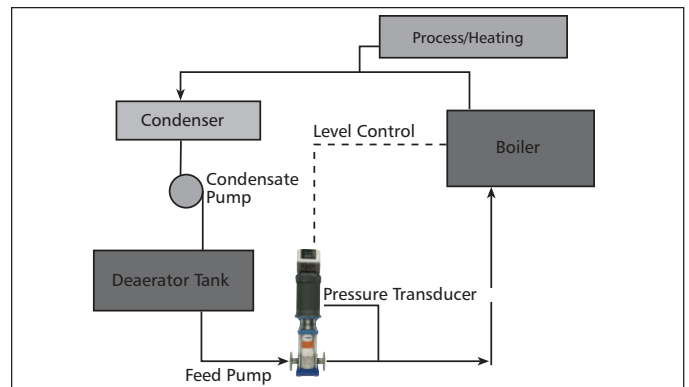

Cooling Tower Circuits

- A thermal sensor can be used as an option to a constant pressure system.
- Temperature can be measured at either side of cooling tower or heat exchanger.
- The AQUAVAR controller can be programmed to increase pump speed to compensate for higher demand with higher temperature input.

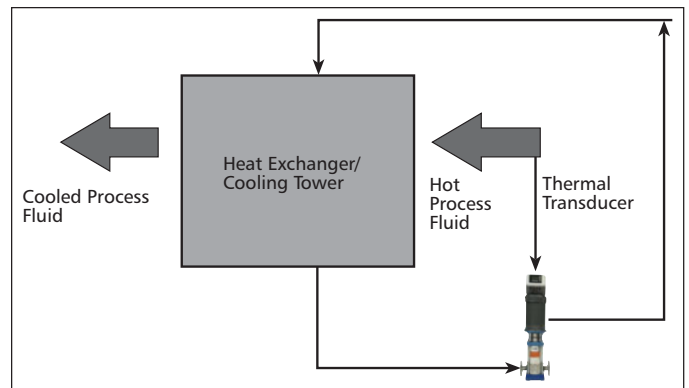

Pump Control Applications

Plastic Injection Molding Machines

- Mold heaters are arranged on multiple headers with the molding machines.
- As each molding machine is turned on, the AQUAVAR controller speeds up the pump(s) to maintain constant pressure in the system.
- The AQUAVAR controller system protects the pump systems from water hammer surges as molds are heated and purged.

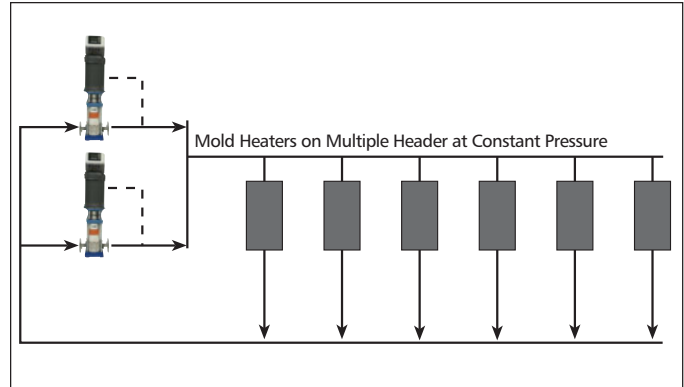

HVAC Circulating Systems

- Automatically adjusts speed to meet demand from additional heating/cooling zones.
- Automatically compensates for system piping losses at higher flows.
- Maintains constant system flow.
- Reduces energy wasted at low flow conditions.
- No pressure transducer required.

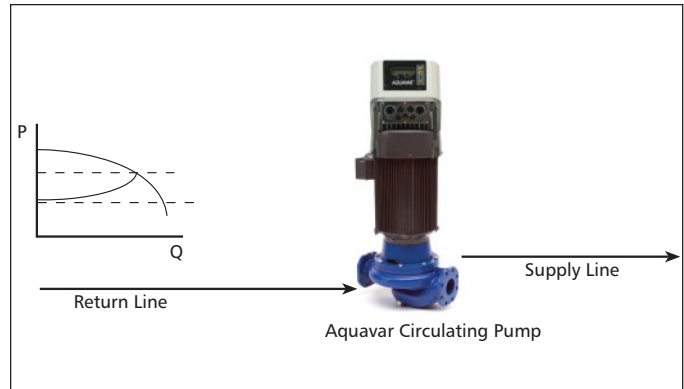

Constant Pressure Municipal Water Supply

- Multi-pump constant pressure booster sets for residential or commercial water supply.
- Ideal for new developments, end of main line service, or higher elevations.
- Automatic reaction to changes in demand for constant point of use water pressure.
- The AQUAVAR controller system provides automatic lead/lag of pumps for even wear.
- Controls pumps based on system requirements.

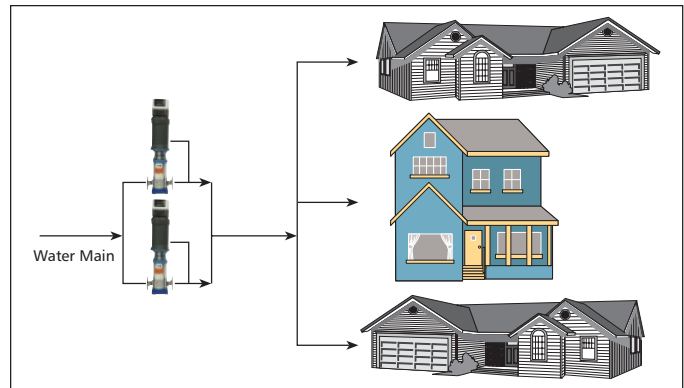

Landscape, Turf and Agricultural Irrigation

- Constant pressure matched to sprinkler head requirements.
- Automatic compensation for number of zones in use.
- Automatic system curve compensation for friction losses at higher flows.
- Automatic start and stop of multiple pumps to keep energy costs low.



Pump Control Applications

Seal Flush Barrier Fluid

- Seal flush circuit can be hooked up to multiple pumps in a process. The AQUAVAR controller automatically compensates for the number of pumps in use.
- Barrier fluid pressure can be set to maintain at 15 PSI over pump pressure.
- Automatically shuts down the pump at zero demand.

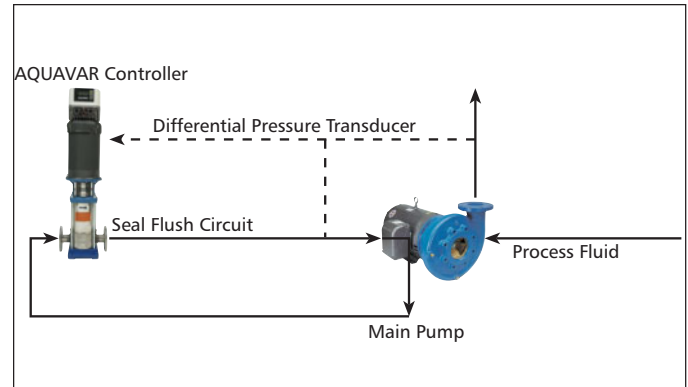

Spray Wash Systems

- Maintains constant pressure at each nozzle.
- Automatic shut off at zero demand to eliminate pump damage.
- Automatic friction loss compensation at higher flows.
- Eliminates by-pass lines, holding tanks and metering valves.

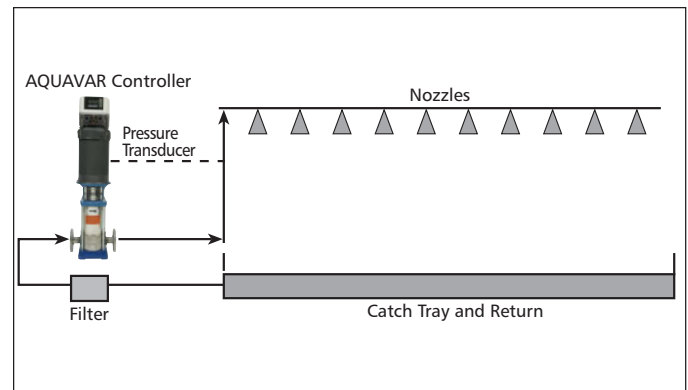

Water Fountain Control

- Uses 4-20 mA anemometer (wind speed indicator) to regulate pump speed. As wind speed increases, fountain spray height decreases to keep water in the fountain.
- Automatically regulates display height depending on wind speed.
- Keeps pedestrians dry.



Snow Making Systems

- Snow guns have a specific operating pressure to optimize their effectiveness. Booster sets for each zone of the mountain can match these requirements better than one pump at the bottom of the mountain.
- Zones can be turned on or off independently to meet ski requirements.
- The main supply pump can be reduced in size since it no longer has to provide snow gun pressure. It can also be equipped with an AQUAVAR controller.

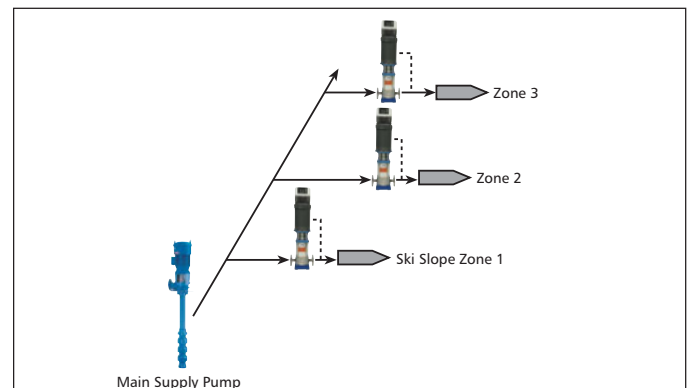

Suggested Pump Selection for VFD Operation

Performance: Locate the pressure (TDH) you wish to maintain and the maximum flow you need. Select the pump which meets or exceeds this rating at full speed (the top line of the range curve). For multi-pump systems, the total capacity of all pumps should meet or exceed the total demand. For constant flow applications, find the flow you wish to maintain and then select the pump size which can meet or exceed the maximum required pressure at full speed. Best results are obtained when the maximum pressure or flow is within ten points of the best pump efficiency. This diagram can be used as a reference in selecting proper pump curves for operation with the AQUAVAR controller.

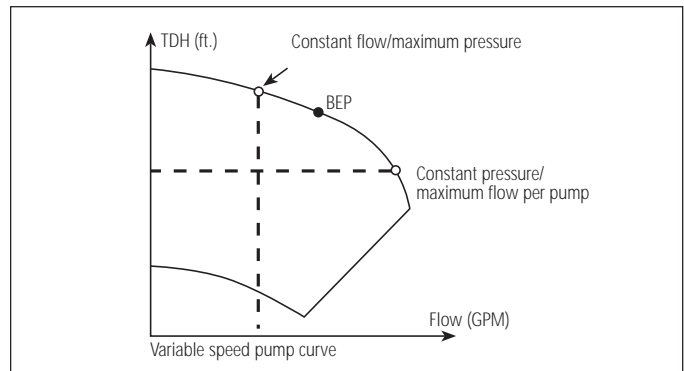

Typical System Design

The following diagrams show typical single pump and multi-pump systems using the AQUAVAR controller. Connection can be made directly to a water supply or water can be drawn from a supply tank or well. In the case of supply tanks and wells, float valves (item 10) can be used to shut down the pumps when water is low. In the direct connection, a pressure switch on the suction side (item 8) can be used.

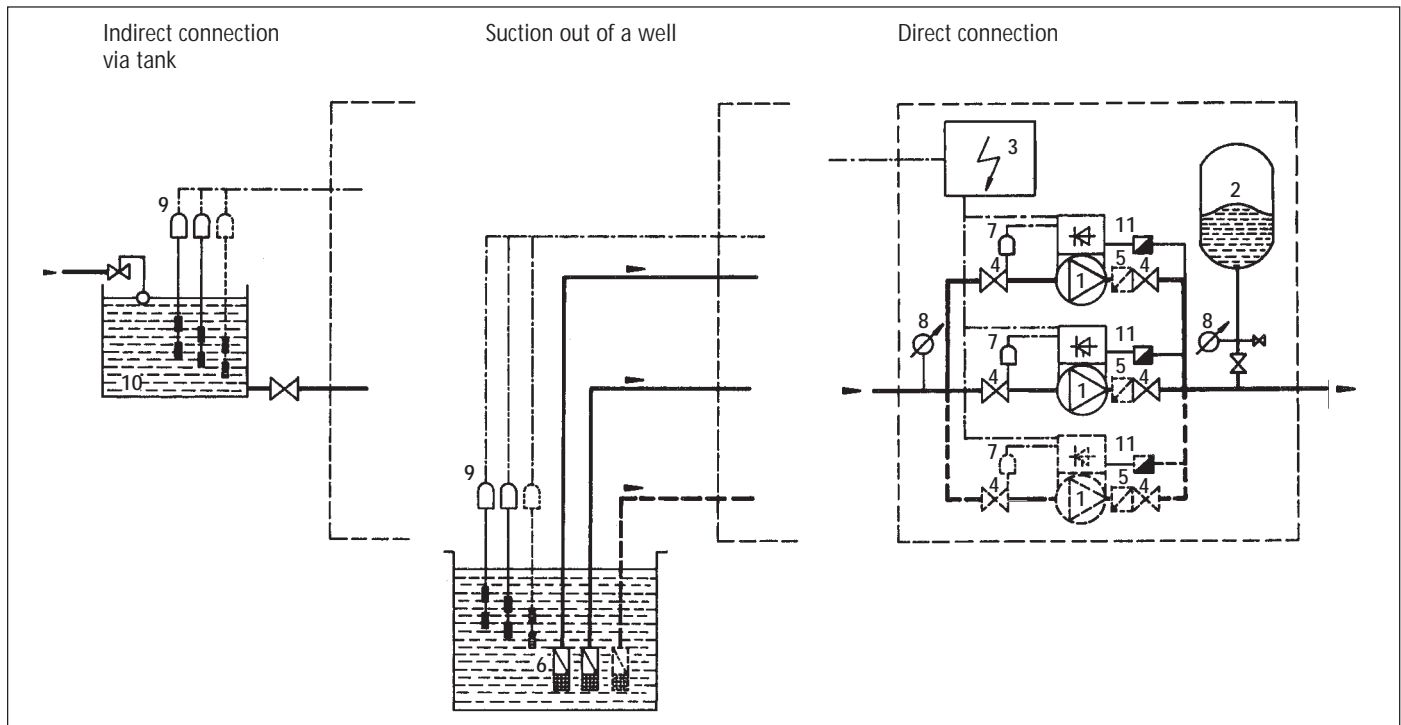

Diagram 2 Multiple Pump Layout

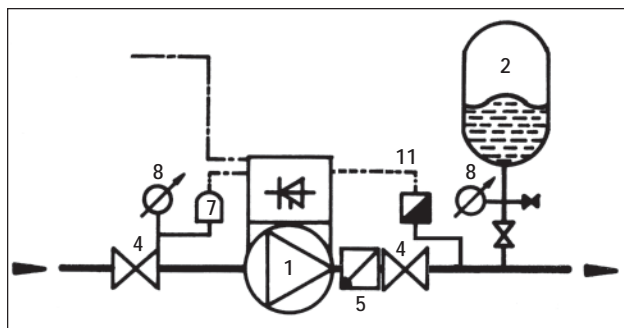

Diagram 3 Single Pump Layout

- 1 Pump with AQUAVAR controller
- 2 Diaphragm tank
- 3 Distribution panel
- 4 Gate valves
- 5 Check valves
- 6 Foot valves
- 7 Incoming pressure switch
- 8 Pressure gauges
- 9 Level switches
- 10 Supply tank
- 11 Pressure Transmitter

A diaphragm pressure tank is used on the discharge side of the pump or pumps to maintain pressure in the line when there is no demand. This will keep the pumps from continuing to run. With the AQUAVAR controller, it is not necessary to have a large tank for supply purposes. In selecting a tank, make sure it can withstand maximum system pressure. The tank should have a total volume of about 10% of the maximum single pump flow rate in gpm. Pre-charge the tank based on required system pressure. Please refer to the chart located in the Installation Programming and Operation manual.

NOTE: Closed loop circulator systems may not require a pressure tank.

Typical Applications

The AQUAVAR controller is specifically designed to control systems using Centrifugal pumps in applications such as:

- Booster systems
- Municipal water supply
- Water treatment
- HVAC
- Irrigation
- OEM packages
- Boiler feed
- Circulation systems
- Fluid level control
- Filtration systems
- Wash systems
- Temperature control



AQUAVAR, G&L Pumps and Goulds Pumps are trademarks and tradenames of ITT Industries or its subsidiary.

www.goulds.com