



Submersible Effluent Pump

MODEL 3885

WE Series

PROSURANCE AVAILABLE FOR RESIDENTIAL APPLICATIONS.

APPLICATIONS

Specifically designed for the following uses:

- Homes
- Farms
- Trailer courts
- Motels
- Schools
- Hospitals
- Industry
- Effluent systems

SPECIFICATIONS

Pump

- Solids handling capabilities: $\frac{3}{4}$ " maximum.
- Discharge size: 2" NPT.
- Capacities: up to 140 GPM.
- Total heads: up to 128 feet TDH.
- Temperature: 104°F (40°C) continuous 140°F (60°C) intermittent.
- See order numbers on reverse side for specific HP, voltage, phase and RPM's available.

FEATURES

- **Impeller:** Cast iron, semi-open, non-clog with pump-out vanes for mechanical seal protection. Balanced for smooth operation. Silicon bronze impeller available as an option.
- **Casing:** Cast iron volute type for maximum efficiency. 2" NPT discharge.
- **Mechanical Seal: SILICON CARBIDE VS. SILICON CARBIDE** sealing faces. Stainless steel metal parts, BUNA-N elastomers.

■ **Shaft:** Corrosion-resistant, stainless steel. Threaded design. Locknut on all models to guard against component damage on accidental reverse rotation.

■ **Fasteners:** 300 series stainless steel.

■ Capable of running dry without damage to components.

■ Designed for continuous operation when fully submerged.

MOTORS

■ Fully submerged in high-grade turbine oil for lubrication and efficient heat transfer.

■ Class B insulation on $\frac{1}{3}$ - $1\frac{1}{2}$ HP models.

■ Class F insulation on 2 HP models.

Single phase (60 Hz):

- Capacitor start motors for maximum starting torque.
- Built-in overload with automatic reset.
- SJTOW or STOW severe duty oil and water resistant power cords.
- $\frac{1}{3}$ and $\frac{1}{2}$ HP models have NEMA three prong grounding plugs.
- $\frac{3}{4}$ HP and larger units have bare lead cord ends.

Three phase (60 Hz):

- Class 10 overload protection must be provided in separately ordered starter unit.
- STOW power cords all have bare lead cord ends.

■ **Designed for Continuous Operation:** Pump ratings are within the motor manufacturer's recommended working limits,

can be operated continuously without damage when fully submerged.

■ **Bearings:** Upper and lower heavy duty ball bearing construction.

■ **Power Cable:** Severe duty rated, oil and water resistant. Epoxy seal on motor end provides secondary moisture barrier in case of outer jacket damage and to prevent oil wicking. Standard cord is 20'. Optional lengths are available.

■ **O-ring:** Assures positive sealing against contaminants and oil leakage.

AGENCY LISTINGS



Tested to UL 778 and CSA 22.2 108 Standards By Canadian Standards Association File #LR38549

Goolds Pumps is ISO 9001 Registered.

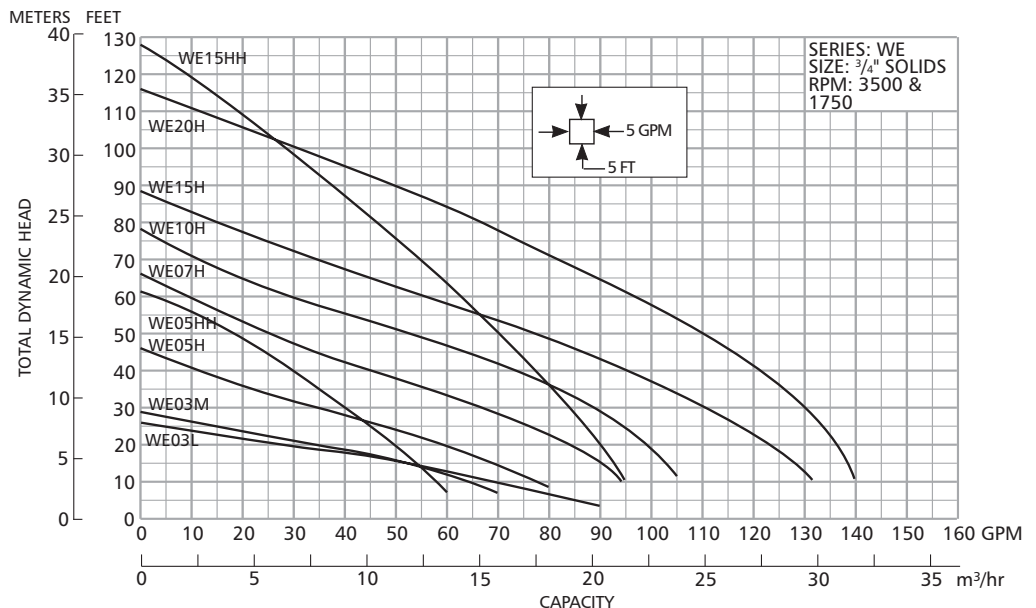

Submersible Effluent Pump

MODEL 3885

WE Series

COMPONENTS

Item No.	Description
1	Impeller
2	Casing
3	Mechanical Seal
4	Motor Shaft
5	Motor
6	Ball Bearings
7	Power Cable
8	Casing O-Ring

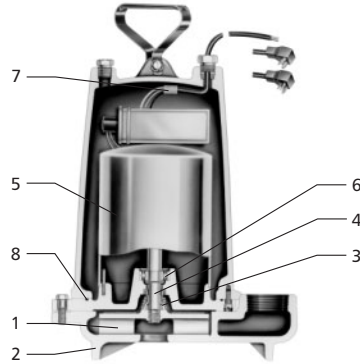

MODELS

Order No.	HP	Volts	Phase	Max. Amp.	RPM	Solids	Wt. (lbs.)
WE0311L	1/3	115	1	10.7	1750	3/4"	56
WE0318L		208		6.8			
WE0312L		230		4.9			
WE0311M		115		10.7			
WE0318M		208		6.8			
WE0312M		230		4.9			
WE0511H	1/2	115	3	14.5	3500	3/4"	60
WE0518H		208		8.1			
WE0512H		230		7.3			
WE0538H		200		4.9			
WE0532H		230		3.3			
WE0534H		460		1.7			
WE0537H	1/2	575	1	1.4	3500	3/4"	70
WE0511HH		115		14.5			
WE0518HH		208		8.1			
WE0512HH		230		7.3			
WE0538HH		200		4.9			
WE0532HH		230		3.6			
WE0534HH	460	1.8					
WE0537HH	575	1.5					
WE0718H	3/4	208	3	11.0	3500	3/4"	80
WE0712H		230		10.0			
WE0738H		200		6.2			
WE0732H		230		5.4			
WE0734H		460		2.7			
WE0737H		575		2.2			
WE1018H	1	208	1	14.0	3500	3/4"	83
WE1012H		230		12.5			
WE1038H		200		8.1			
WE1032H		230		7.0			
WE1034H		460		3.5			
WE1037H		575		2.8			
WE1518H	1 1/2	208	3	17.5	3500	3/4"	83
WE1512H		230		15.7			
WE1538H		200		10.6			
WE1532H		230		9.2			
WE1534H		460		4.6			
WE1537H		575		3.7			
WE1518HH	1 1/2	208	1	17.5	3500	3/4"	83
WE1512HH		230		15.7			
WE1538HH		200		10.6			
WE1532HH		230		9.2			
WE1534HH		460		4.6			
WE1537HH		575		3.7			
WE2012H	2	230	3	18.0	3500	3/4"	83
WE2038H		200		12.0			
WE2032H		230		11.6			
WE2034H		460		5.8			
WE2037H		575		4.7			

PERFORMANCE RATINGS (gallons per minute)

Order No.	WE03L	WE03M	WE05H	WE07H	WE10H	WE15H	WE05HH	WE15HH	WE20H
HP	1/3	1/3	1/2	3/4	1	1 1/2	1/2	1 1/2	2
RPM	1750	1750	3500	3500	3500	3500	3500	3500	3500
5	86	-	-	-	-	-	-	-	-
10	70	63	78	-	-	-	58	-	-
15	52	50	70	90	-	-	53	-	-
20	27	35	60	83	98	123	49	90	136
25	-	-	48	76	94	117	45	87	133
30	-	-	35	67	88	110	40	83	130
35	-	-	20	57	82	103	35	80	126
40	-	-	-	45	74	95	30	77	121
45	-	-	-	35	64	86	25	74	116
50	-	-	-	25	53	77	-	70	110
55	-	-	-	-	40	67	-	66	103
60	-	-	-	-	30	56	-	63	96
65	-	-	-	-	20	45	-	58	89
70	-	-	-	-	-	35	-	55	81
75	-	-	-	-	-	25	-	51	74
80	-	-	-	-	-	-	-	47	66
90	-	-	-	-	-	-	-	37	49
100	-	-	-	-	-	-	-	28	30

DIMENSIONS

(All dimensions are in inches. Do not use for construction purposes.)

